

EXPLODED VIEW

No.	Beskrivelse	Description	Beschreibung	Part No.
1	Betjeningsknap, venstre. og højre	Control button, left and right	Drehknopf, links und rechts	AR005-178-TZ001
# 2	Bund	Base	Ständer	AR005-022-TZ0xx
2.1	Sikring 2,5 Amp. træg, 230V	Fuse 2,5 A, slow, 230V	Sicherung 2,5 A, träge, 230V	R20E-418.6
2.2	Sikring 5 Amp. træg, 100/110V	Fuse 5 A, slow, 100/110V	Sicherung 5 A, träge, 100/110V	AR005-418-00001
3	Bundplade	Cover plate	Bodenplatte	AR005-347-TZ001
4	Kabel	Cable	Kabel	AR005-193-TZ001
5	Kipleje, venstre. og højre	Tilt bearing, left and right	Kipplager, links und rechts	AR005-337-TZ001
# 6	Låg	Lid	Deckel	AR005-024-TZ0xx
7	Mellemaksel	Intermediate shaft	Zwischenwelle	AR005-325-TZ001
# 8	Overdel	Upperpart	Oberteil	AR005-023-TZ0xx
9	Rigel	Lockpin	Riegel	AR005-332-TZ001
10	Rørehoved	Planetary head	Rührkopf	AR005-002-TS001
10.1	Tandkrans	Toothed wheel rim	Zahnkranz	AR005-001-TD001
11	Styring	Control board	Steuerung	AR005-378-TS001
* 12A	Transformer 110V	Transformer 110V	Transformator 110V	AR005-368-TZ001
* 12B	Transformer 100V	Transformer 100V	Transformator 100V	AR005-368-TZ002
13	Transmission og motor	Transmission and motor	Transmission und Motor	AR005-339-TZ001
13.1	Poly-V rem og skive	Poly-V belt and pulley	Poly-V Keilriemen und Scheibe	AR005-090-TZ001
13.2	Poly-V rem	Poly-V belt	Poly-V Keilriemen	AR005-090-TD001
14	Udløser	Release housing	Auslöser	AR005-372-TS001
15	Vægtudligner	Weight compensator	Gewichtskompensator	AR005-352-TZ001
16	Hjælpetræk	Attachment drive	Anschlussgetriebe	AR005-010-TZ001
17	Maskinfødder	Machine feet	Maschinenfüsse	AR005-213-TS020
18	Fastspænding af kedel	Fixing of bowl	Festspannung des Kessels	AR005-340-TZ001
19	Kedellås	Bowl lock	Kesselsperre	AR005-336-TS010

Old version of frequency inverter

* 12A/12B kun når styrestrøm er lavere end 220V
12A/12B only when pilot current is lower than 220V
12A/12B nur wann Steuerleitung niedriger als 220V ist

Opgiv venligst farve ved bestilling
Please state the color when ordering
Geben Sie bitte die Farbe bei Bestellung

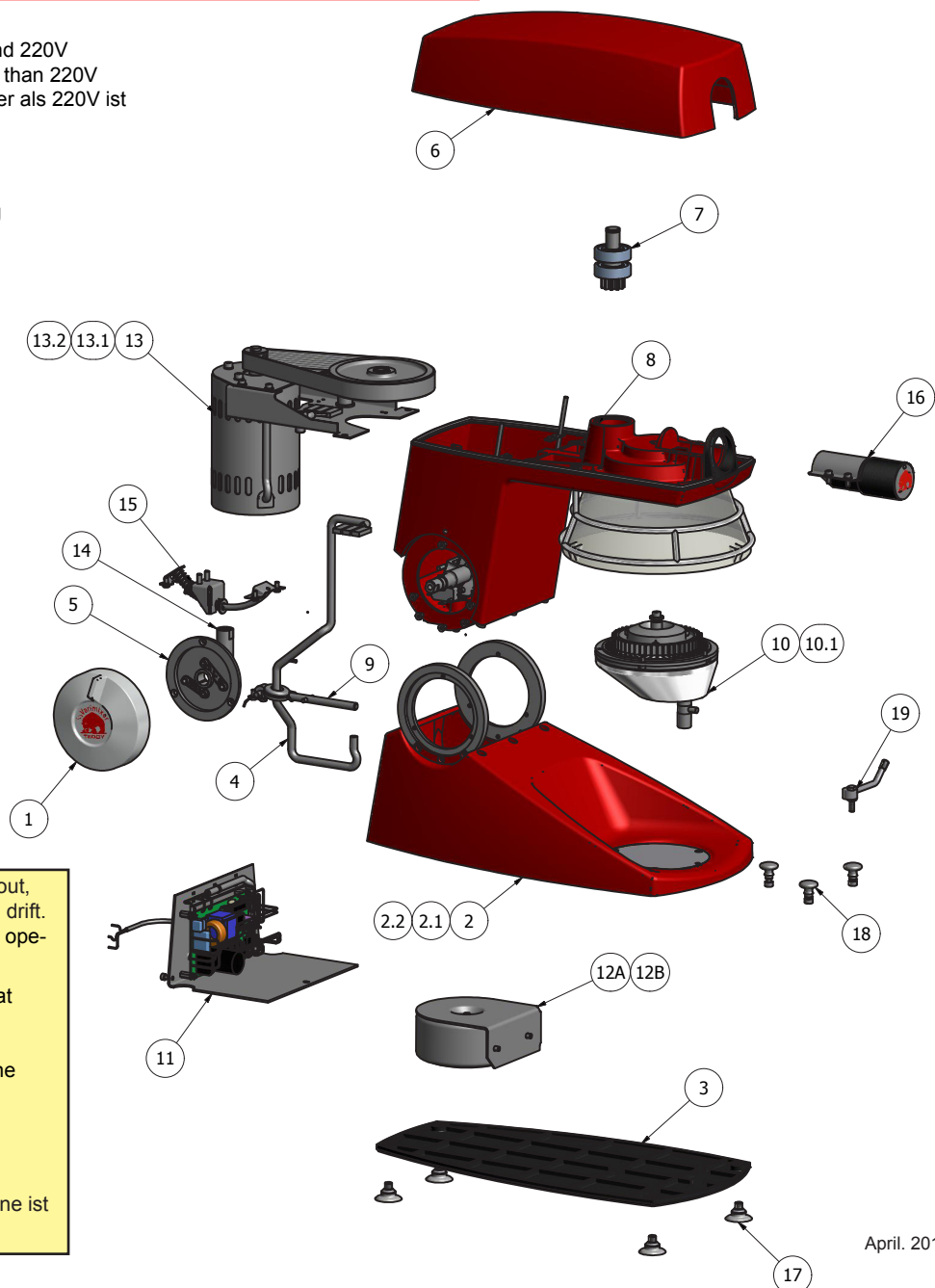

Maskinen er udstyret med en sikkerheds-timeout, der slukker maskinen efter 45 min. kontinuerlig drift. Det vedvarende lydniveau ved maskinen er for operatøren maksimalt 70 dB (A).

The mixer is equipped with a safety-timeout that turns off the mixer after 45 minutes continuous operation. The constant noise level of the workplace of the operator is lower than 70 dB (A).

Die Maschine ist mit einer Sicherheitszeituhr versehen, die die Maschine nach 45 Min. kontinuierlichem Betrieb abschaltet. Das dauernde Geräuschniveau bei der Maschine ist für den Benutzer höchstens 70 dB (A).

EQUIPMENT

STACKABLE BOWLS



LID FOR BOWL



WHIP



HOOK



BEATER

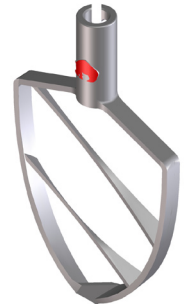

SPLASH GUARD



FILLING SKID

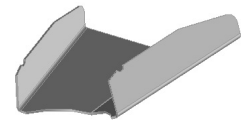

MEAT MINCER:3MM

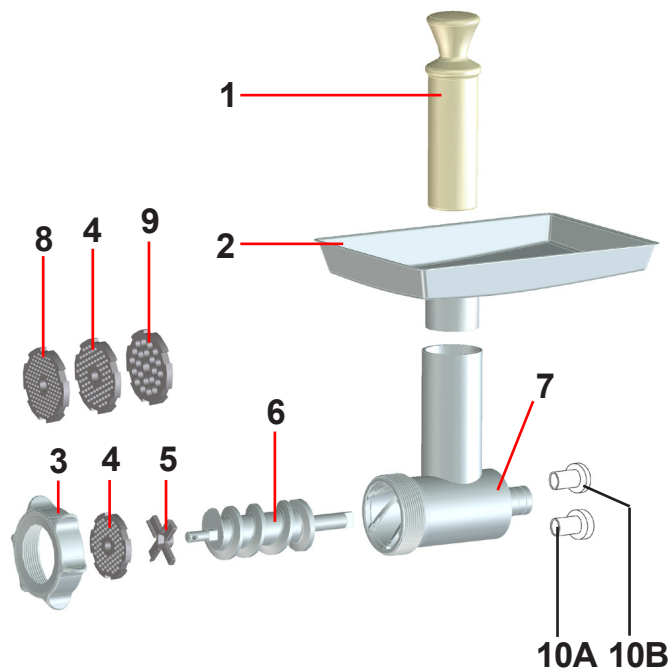

SPARE PART LIST:

- 1. Plunger.....AR005-364-TD001
- 2. Meat TrayAR005-363-TD001
- 3. RingAR005-355-TD001
- 4. Disc with 4mm holes (included)AR005-357-TD002
- 5. CutterAR005-358-TD002
- 6. Feed screwAR005-356-TD001
- 7. Housing.....AR005-359-TD002
- 8. Disc with 3mm holesAR005-357-TD001
- 9. Disc with 8mm holes (included)AR005-357-TD003
- 10A. Bearing bush-standard tighteningAR005-362-TD001
- 10B. Bearing bush-manual tightening..... 3VC-390C