

Varimixer

EASYLIFT 30-60

LIFTING HEIGHT The Easylift 30-60 lifts bowls from 13,5 to 108 cm for suitable working height.

BOWL SIZES The Easylift 30-60 handles bowl from 30 to 60L.

EASY TRANSPORTATION EASYLIFT handles all lifts of bowls and is easy to drive around in the kitchen.

OVERLOAD PROTECTION The lift is equipped with overload protection and a safety clutch.

EASY HANDLING After mixing, the bowl is lifted directly out of the mixer, driven to the workplace and lifted up to appropriate working height for portioning of the contents.

BATTERY POWERED The Easylift 30-60 lift will enhance efficiency in your work processes and ensure health and safety.

MAXIMUM LOAD Easylift 30-60 moves, lifts and handles loads of up to 70 kg simply and efficiently.

EASY OPERATION The fingertip control switchgear, makes it possible to operate the lifter from many positions.

WHEN NOT IN USE When EASYLIFT is not in use, it can be parked under the table.



VARIMIXER EASYLIFT 30-60

The masts and covers are made of anodized aluminium.

The handlebars and legs are made of steel.

The sledge is made of electro-galvanized steel.

Charger: 230V, 1,8 Amps

CERTIFICATIONS



VARIMIXER EASYLIFT 30-60

Bowl size	30 - 60 L
Maximum load	70 kg
Net weight	27 kg
H x W x L	1224 x 447 x 869 mm
Batteries	24V, 7,2Ah
Charging time (100%)	8 hrs.
Sound pressure level	≤ 70 Db(A)
Vibration strength	≤ 2.5 m/s ²
IP code	IP41

DIMENSIONS

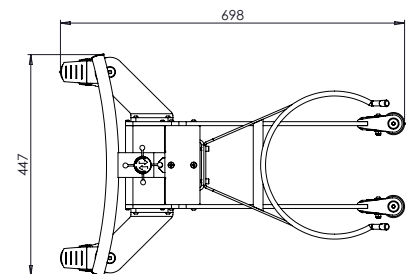
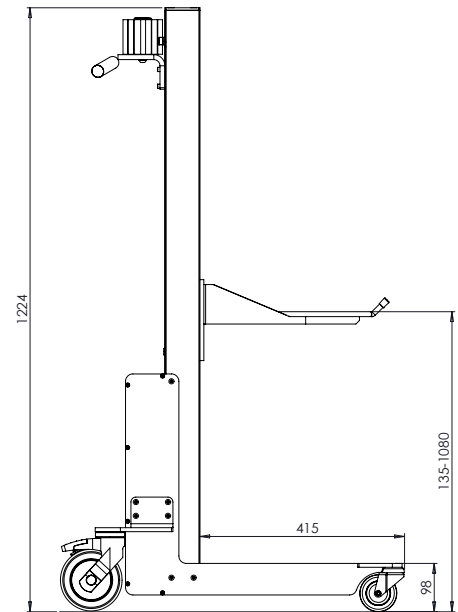
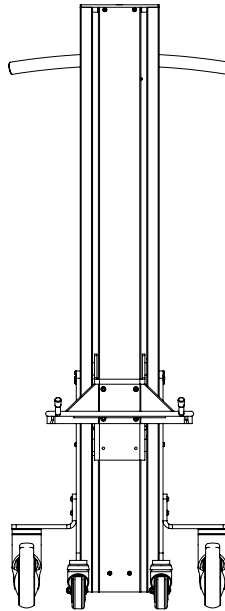
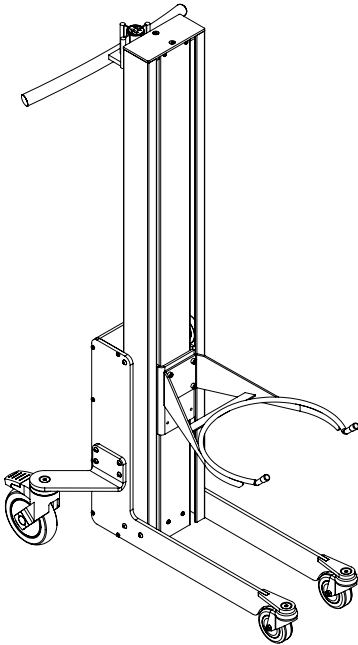

Varimixer

Varimixer A/S
Elementfabrikken 9
DK-2605 Brøndby
P: +45 4344 2288
E: info@varimixer.com
www.varimixer.com