

AR80 VL-1



Spare parts manual

Valid from machine number:
80002012

Varimixer

Varimixer A/S
Elementfabrikken 9
DK-2605 Brøndby
Denmark

P: +45 4344 2288
E: info@varimixer.com
www.varimixer.com

DRN: 24080-1302
2022 11 09

EN

SPEED REGULATION.....	3
TRANSMISSION	4
PLANETARY HEAD	6
MACHINE COLUMN.....	8
SAFETY GUARD	10
LIFTING SYSTEM	12
ATTACHMENT DRIVE.....	14
MICROSWITCHES	16
CABLES.....	17
ELECTRIC COMPONENTS.....	18
FRONT PANEL ASSEMBLY.....	20
BOWLS AND MIXING TOOLS	22

ORDERING OF SPARE PARTS:

Sales of spare parts for our mixers, are handled in our sales and service department. When ordering spare parts, the following information must be provided:

- 1. Type of machine.**
- 2. Number of the machine.**
- 3. Article number of the spare part in question. (Order no.)**
- 4. Method of conveyance.**

If one of the above pieces of information is missing, please contact our sales and service department before placing the order, as then we can assist you in finding the correct article number (**order no.**) of the spare part in question.

A few spare parts are not sold alone, in such cases reference is made at the pos.number to the assembly number to be used for ordering. The assembly numbers are shown on the relevant pages.

Returning of spare parts is only allowed when agreed with:

Varimixer A/S

FIG NO.	ORDER NO.	DESCRIPTION
---------	-----------	-------------

2	AR30-47.10	Disc with arrow
3	AR30-47.11	Clamp
4	STA3306	Knob
5	STA3414	Circlip
6	STA5247	Screw
7	STA5439	Screw
8	STA5810	Nut

..... AR81-47Z.....Speed selector assembly

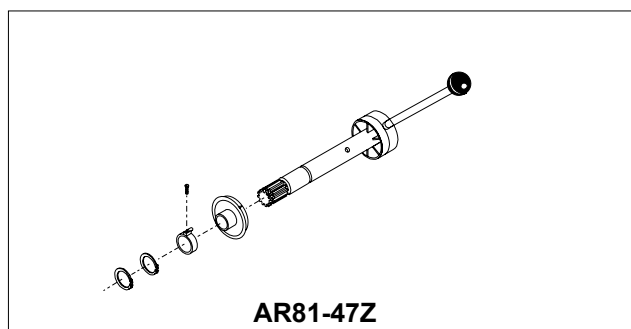
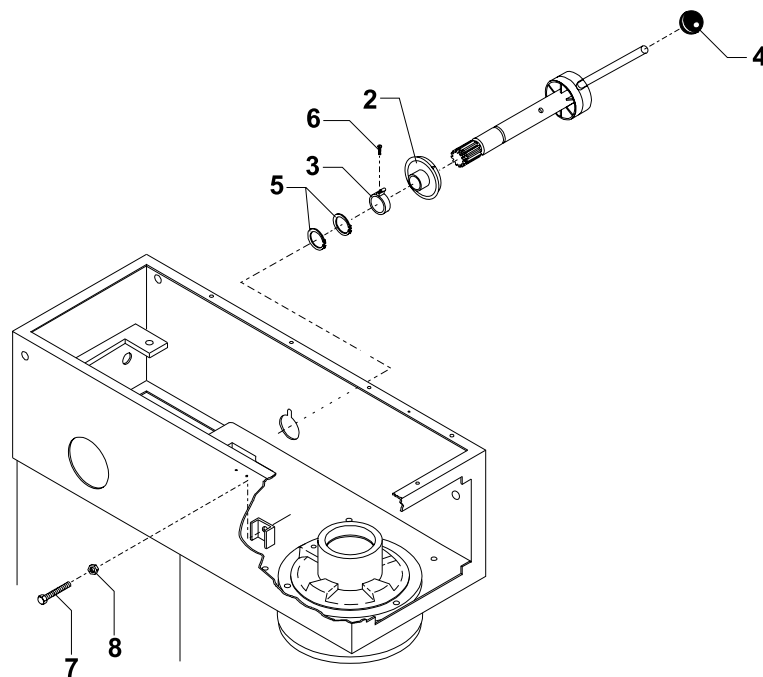

TRANSMISSION

FIG NO.	ORDER NO.	DESCRIPTION
1	STA6018	Washer
7	R100-128	Pulley small
9	STA2024	Feather Key
10	STA3220	Grease nipple
11	STA3410	Circlip
12	6205 2RS	Ball bearing
13	STA3514	Circlip
15	R100-143	Distance bushing
16	R100-6	Bearing arm
17	STA5348	Hex cap screw
18	STA6033	Washer
19	R60-91	V-belt
31	R27-227Z	Clamping ring
32	STA2011	Feather Key
33	STA5018	countersunk head screw
35	R60-61.1E	Base for motor
36	R15-18Z	Bearing bracket
37	STA5810	Hex Nut
38	STA5895	Hex flange nut
38a	STA5812	Hex Nut
39	AR81-305	Stud bolt
40	R20-26.1	Support bracket for belt
41	STA5446	Hex cap screw
42	STA6026	Washer
43	STA5345	Hex cap screw
44	R27-16	Fork for belt tightener, lower
45	R20-19	Fork for belt tightener
46	R20-275	Compression spring
47	R15-46Z	Toothed rack shaft
48	STA5815	Hex Nut
49	STA3407	Circlip
50	STA6040	Washer
51	STA5433	Hex cap screw
52	STA6034	Washer
53	R15-142-USPUL	Grease gun
54	STA6048	Washer
55	*1) R100-129	Belt pulley
55a	*2) R100-129A	
56	STA2030	Feather Key
57	STA3419	Circlip
58	*1) R100-90Z	V-belt
58a	*2) R100-90.1Z	

..... *1) .. 50 Hz power supply

..... *2) .. 60 Hz power supply

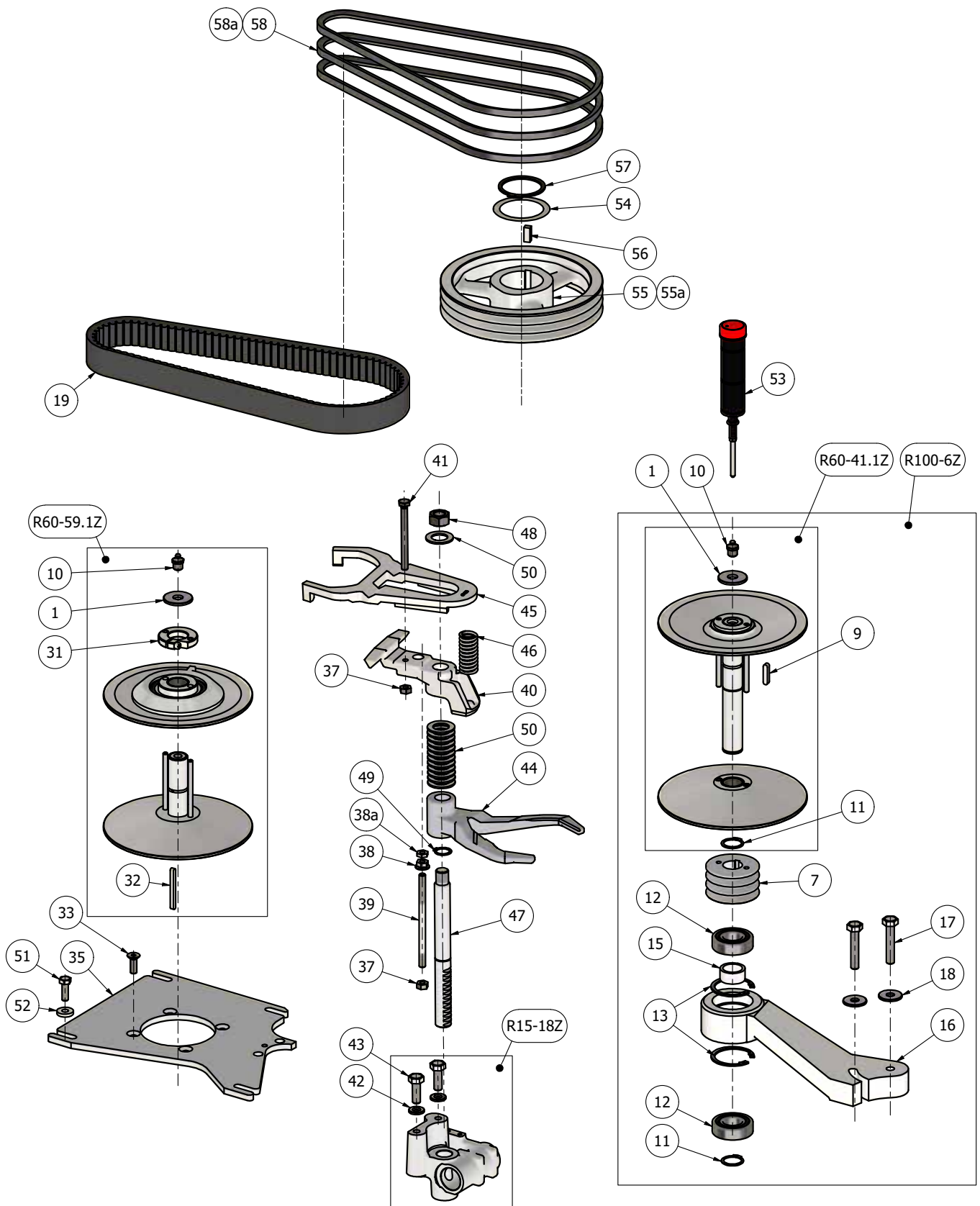

- R60-59.1Z Motor pulley, assembly
- R100-6M..... Pulley bearing arm, assembly
- R60-41.1Z Pulley assembly
- R15-18Z Bearing bracket, assembly

PLANETARY HEAD

FIG NO.	ORDER NO.	DESCRIPTION
.....	*1) .. AR80-2.5M0.....	Planetary head, assembly
.....	*3) .. AR80-2.4MR.....	
.....		
1	R100-101Z.....	Needle bearing, kit
2	*1) .. R100-1	Gear wheel rim
.....	*3) .. R100-1M5.....	
3	*1) .. R100-2Z.....	Eccentric head, kit
.....	*3) .. R100-2M5.....	
4	*1) .. R100-3Z.....	Main bearing, kit
.....	*3) .. R100-3M5.....	
5	STA3532	Circlip
6	R100-30	Main shaft
7	AR140-31.....	Rim pinion
8	R100-32.1	Rim pinion, lower
9	AR101-33.5.....	Bayonet shaft
10	R100-37	Distance piece
11	R100-36.....	Eccentric disc
12	R100-96.....	Needle bearing
13	R100-97	Ball bearing
14	R100-98	Ball bearing
15	R100-99	Ball bearing
18	R100-100	Ball bearing
20	R100-141	Distance tube
22	STA2039	Feather Key
22a	STA2034	Feather Key
23	STA3419	Circlip
24	STA3478	Circlip
25	STA3530	Circlip
27	*1) .. STA5263	Screw
.....	*3) .. STA9003	
28	STA5333	Screw
29	R100-209	Seal ring
30	W100-272	Cap, planetary head
32	AR80-162H	Plastic cap
33	STA5644	Screw
34	STA5652	Screw
36	STA6057	Lock washer
37	STA6460	Grooved pin
40	R100-235	Washer
41	STA6029	Washer
.....		
.....	*1) .. Standard version.....	
.....	*3) .. Stainless steel frame version	
.....		
.....	R100-30Z	Main shaft, kit
*1).....	R100-3Z	Main bearing, kit
.....	AR101-33.5Z.....	Bayonet shaft, kit
*1).....	R100-2Z	Eccentric head, kit
*1).....	RN100-2.1Z	Eccentric head mounted
.....	R100-36Z	Eccentric disc, kit
.....	R100-101Z.....	Needle bearing, kit

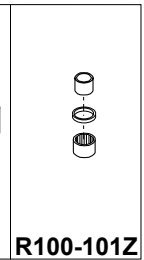
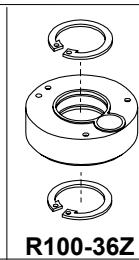
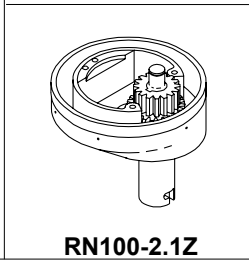
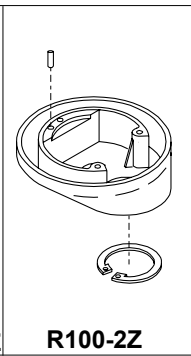
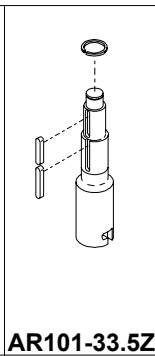
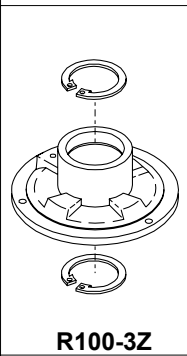
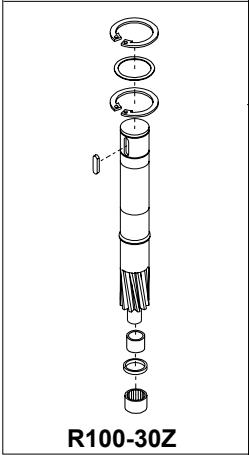
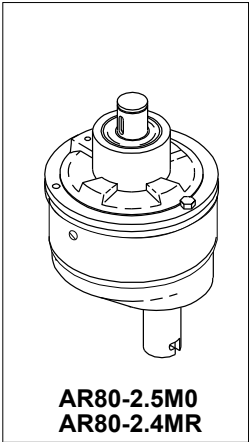
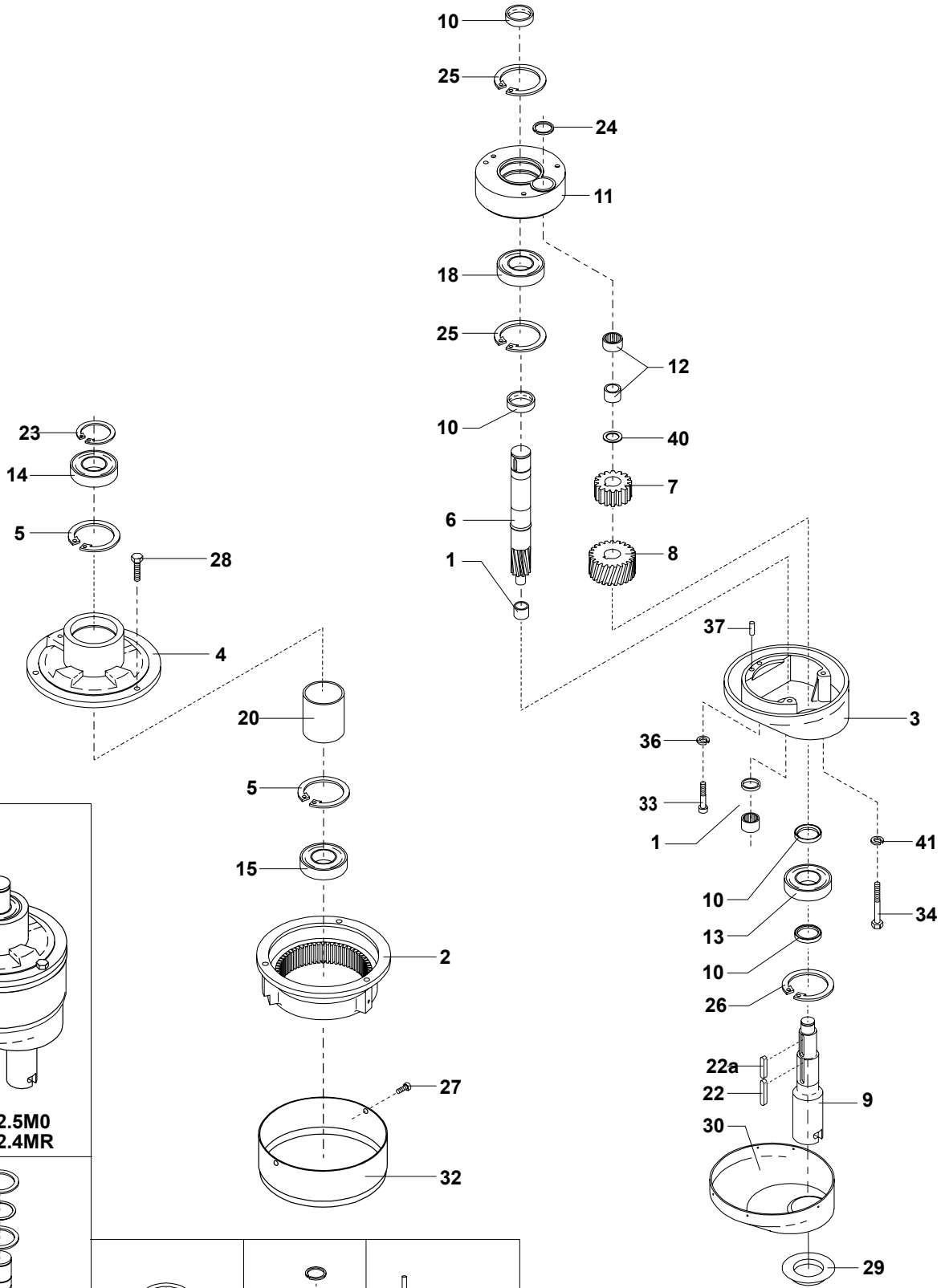

MACHINE COLUMN

FIG NO.	ORDER NO.	DESCRIPTION
1	R15-245	Arrow sign
2	STA3002	Cable gland
3	STA6580	Threaded bushing
4	AR80-212	Blanking plug
5	AR80-213	Base plate
6	STA5045	Screw
7	AR31-22.180	Grate
8	STA6511	Plug button
9	STA2515	Bearing bushing
10	STA2526	Bearing bushing
11	STA5615	Socket head screw
12	AR80-214.6	Adjustment plate, 3mm
13	AR80-214.3	Adjustment plate, 6mm
14	STA3014	Cable gland nut
15	STA5017	Screw
16	STA5080	Screw
17	STA5232	Self tapping Screw
18	AR81-22.17R	Cover plate
19	AR81P-21	Top cover
20	STA5724	Set screw
21	STA5624	Countersunk head screw
22	STA6510	Plug button
23	AR81-270	Cover plate, upper
24	AR81-271	Cover plate, lower
25	STA5897	Hex flange nut
26	STA5322	Hex cap screw
27	STA6056	Lock washer
28	STA5815	Hex nut
29	R20-148	Threaded bushing
30	56AE140-25	Shaft for Safety guard
31	56AE140-25.1	Bracket for Safety guard
32	STA6165	Washer
33	STA6020	Washer
34	AR81-71	Guide plate for bowl arms

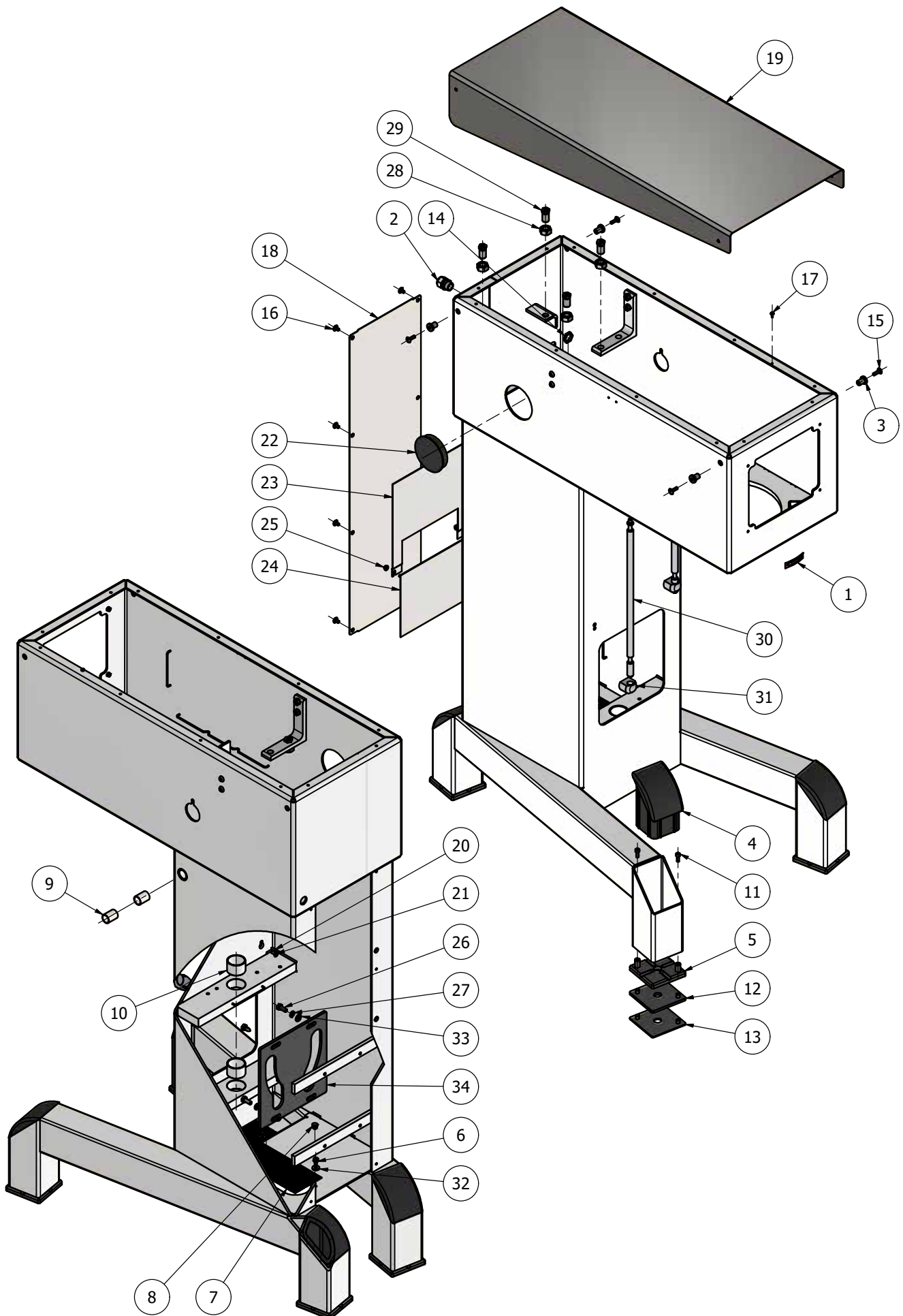

SAFETY GUARD

FIG NO.	ORDER NO.	DESCRIPTION
1	35AR81-21.3M.....	Safety guard left
2	35AR81-22.3M.....	Safety guard right
3	STA3149	O-ring
4	56CE101-280.....	Filling tray

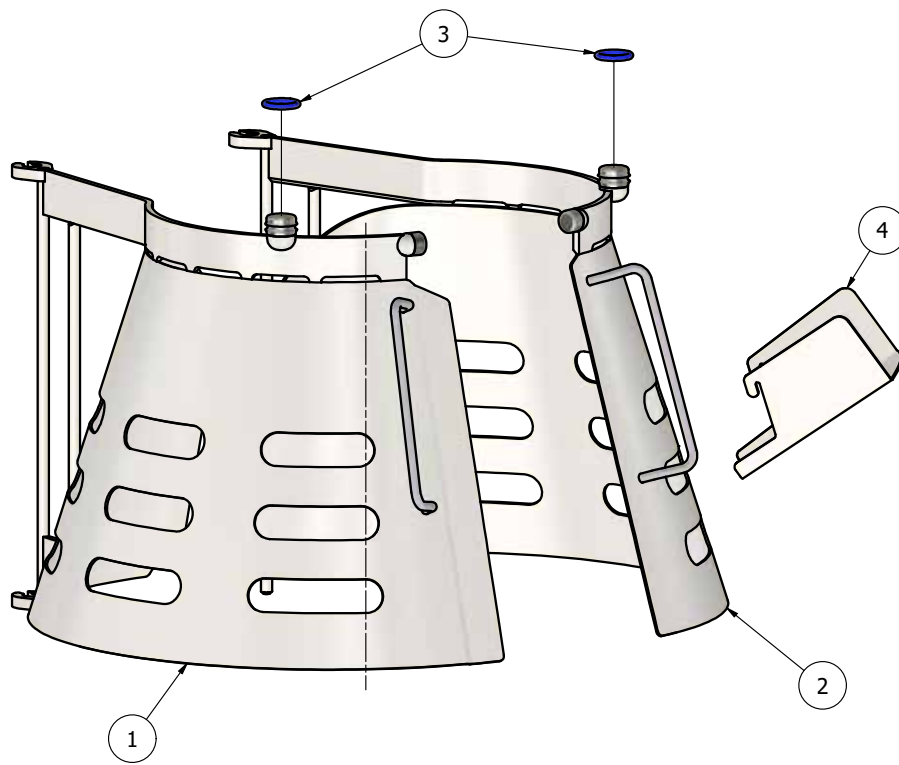

LIFTING SYSTEM

FIG NO.	ORDER NO.	DESCRIPTION
1	AR81-23/24Z	Bowl arm set, colour black
2	AR31-127	Roller shaft
3	AR31-128	roll for bowl clamping
4	STA5088	Screw
5	STA2526	Bearing bushing
6	AR60-84	Eye bolt
7	STA5819	Nut
8	AR81-71.10	Shaft for bowl arm guide
9	AR81-71.5M	Bush for bowl arm guide, mount
10	STA3462	Circlip
11	AR81-68Z	Bowl arm, guide rod
12	AR81-83Z	Lifting bolt
14	AR81-611	shaft
14a	W40-603E	Shaft
15	STA6205	Spring cotter
16	STA3408	Circlip
17	STA6381	Pin
18	AR81-86.42	Bracket
19	STA5322	Screw
20	STA6020	Washer
21	STA6056	Spring lock washer
22	R100-62Z	Lifting lever assy.
23	STA3308	Ball knob
24	STA2020	Key
25	R60-63Z	Crank shaft
26	STA6044	Washer
27	STA3408	Circlip
28	AR40-65M	Lifting nut
29	STA5827	Nut
30	AR81-608	Extender
31	W60-604	Damper
32	R60-110	Lifting spring
	AR81-600.1M	Damper kit

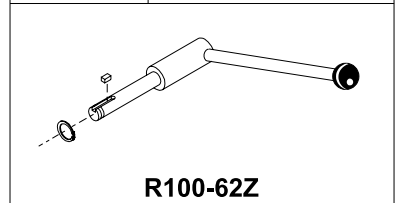
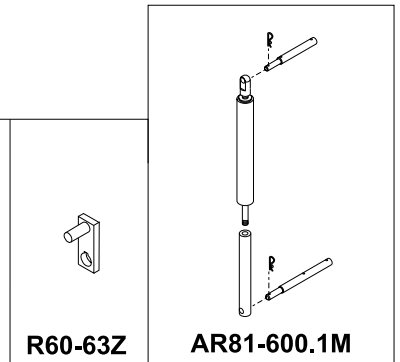
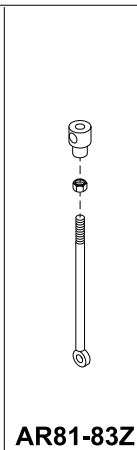
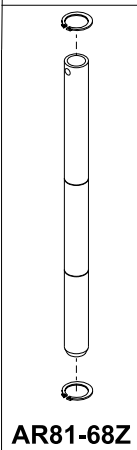
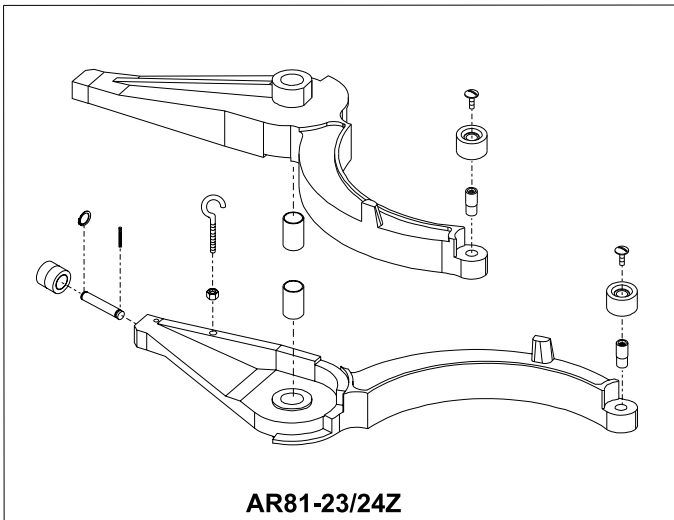
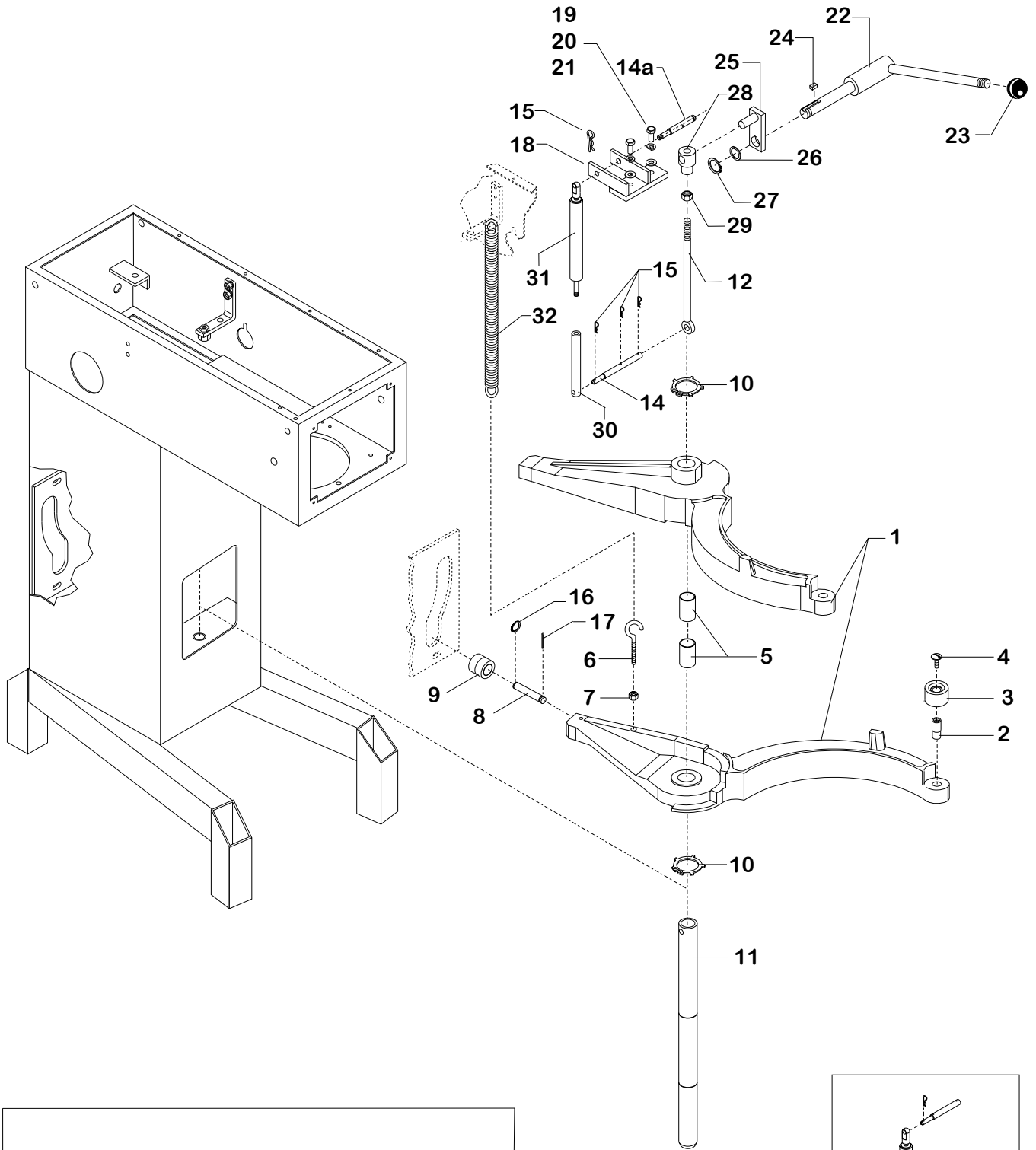

ATTACHMENT DRIVE

FIG NO.	ORDER NO.	DESCRIPTION
1	R15-5	Bearing hub
2	R20-9	Worm wheel
3	R15-10	Gear case
4	R15-11	Gear case cover
5	R20-49	Worm shaft
6	R20-52Z	Gear shaft assembly
7	R15-50Z	Attachment drive shaft assembly
8	STA2032	Key
9	R20-104	Ball bearing
10	R20-107	Oil seal
11	R20-300	Gasket
12	R20-300Z	Gasket kit
13	R20-301	Gasket
14	STA2007	Key
15	STA2011	Key
16	STA3410	Circlip
17	STA5018	Screw
18	6005 2RS	Ball bearing
19	STA5433	Screw
20	STA5908	Seal washer
21	STA6020	Washer
23 + 29	STA6056	Lock washer
24	R15-211	Rubber ring
25	R15-215	End cover
26	R15-8M0	Engagement hub, white
27	STA5322	Screw
28	STA5561	Finger screw
29	R20-249	Label, "Greased for life"
30	STA6316	Pin

..... AR60-10Z..... Attachment drive assy.
..... AR60-10.5Z..... Attachment drive mounted
..... R30-10.5M Gear case assy.
..... R15-8Z Attachment hub assy. white

..... Identification of motor, see page 18.

31 ..Drive unit, cable included

..... **Motor R100-85.1, 2,9 kW**
..... 07080-2930
..... 07080-2930R stainless steel frame version
..... **Motor R100-85.52, 3 kW, 3x200/50-3x208/60**
..... 07080-3030
..... 07080-3030R stainless steel frame version

32 ..Drive unit with attachment Drive, cable included

..... **Motor R100-85.1, 2,9 kW**
..... 07080-2941
..... 07080-2941 ... stainless steel frame version
..... **Motor R100-85.52, 3 kW, 3x200/50-3x208/60**
..... 07080-3042
..... 07080-3042R stainless steel frame version

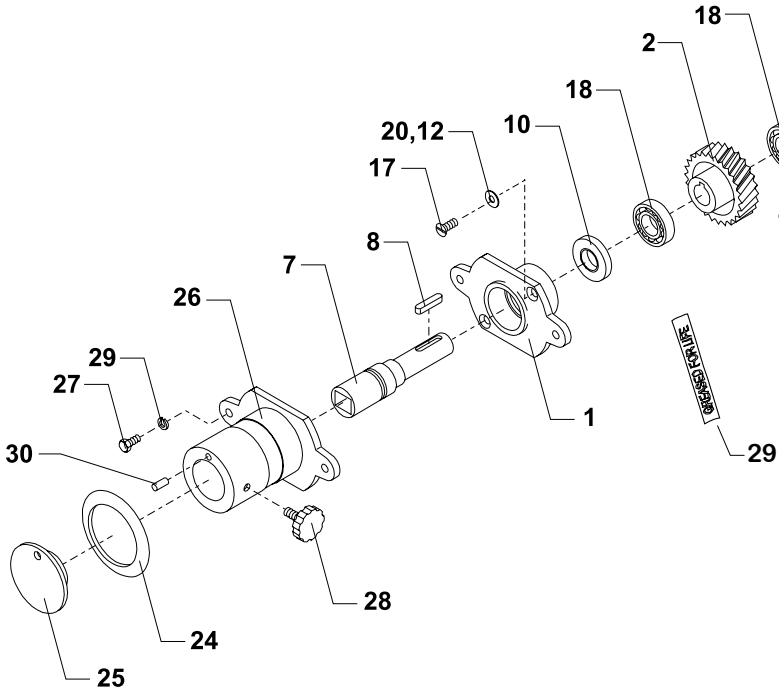
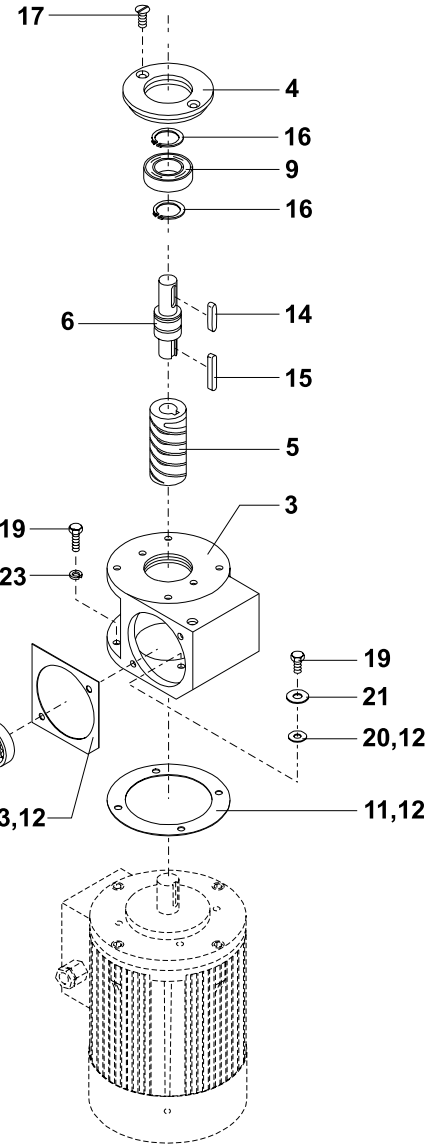
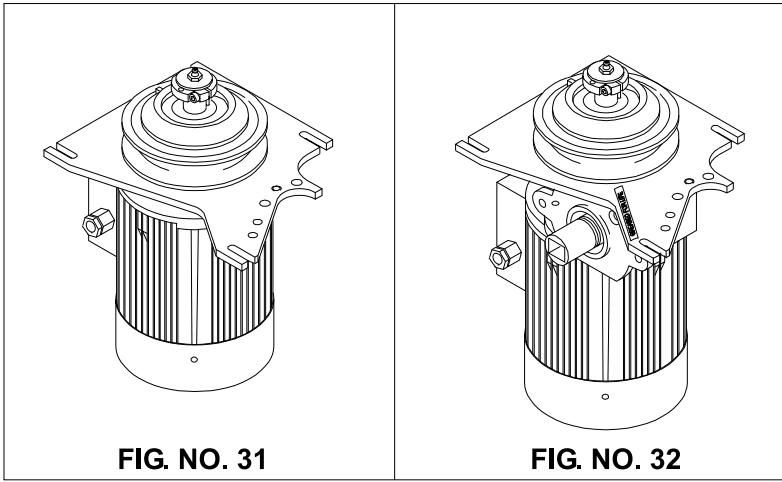

<p>R15-8Z</p>	<p>AR60-10.5Z</p>	<p>R30-10.5M</p>	<p>R20-300Z</p>	<p>R15-50Z</p>
<p>AR60-10Z</p>		<p>R20-52Z</p>		

MICROSWITCHES

FIG NO.	ORDER NO.	DESCRIPTION
1	56CR10-111M	Safety Switch
2	STA5320	Hex cap screw
3	STA5837	Lock Nut
4	STA5721	Hex cap screw

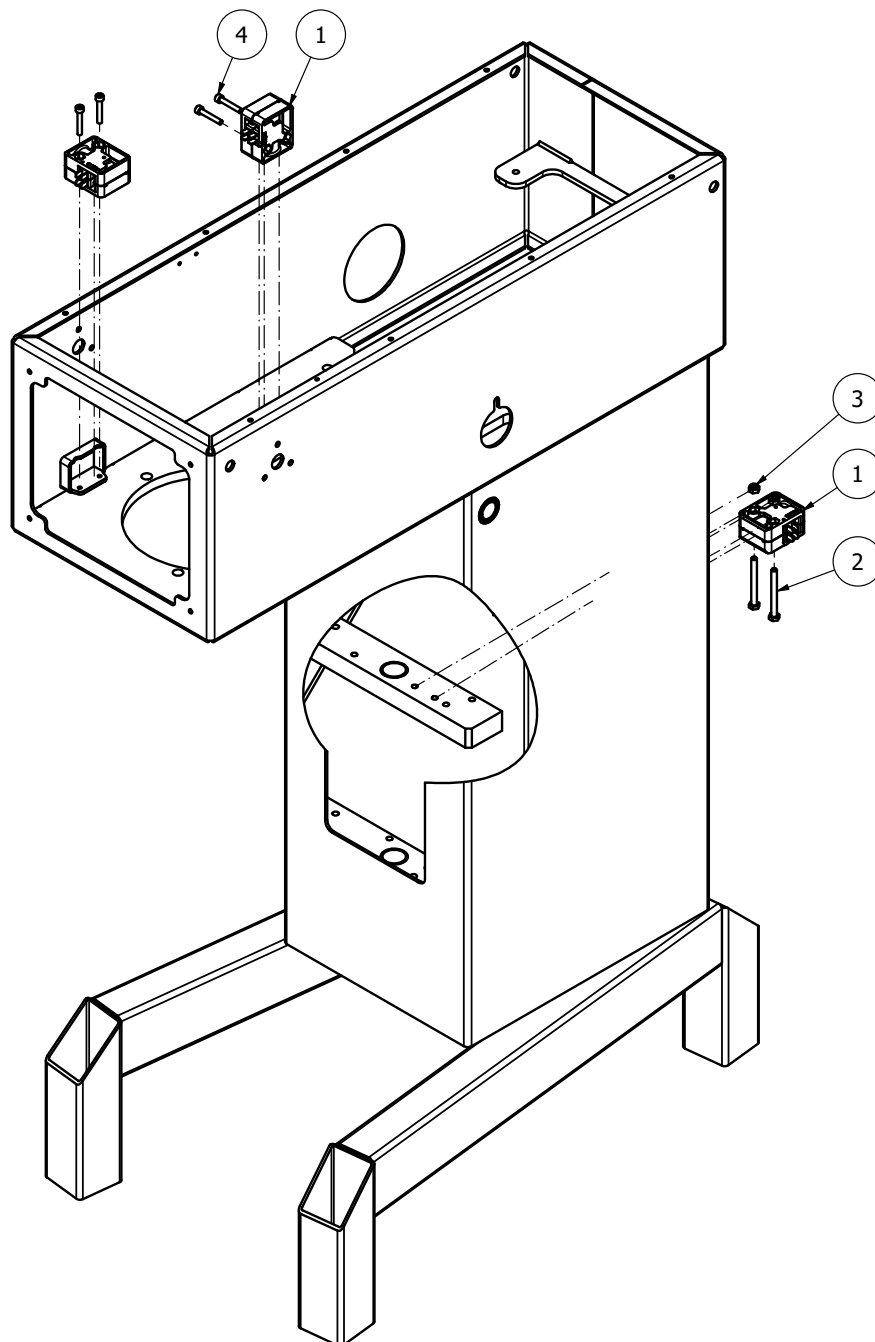
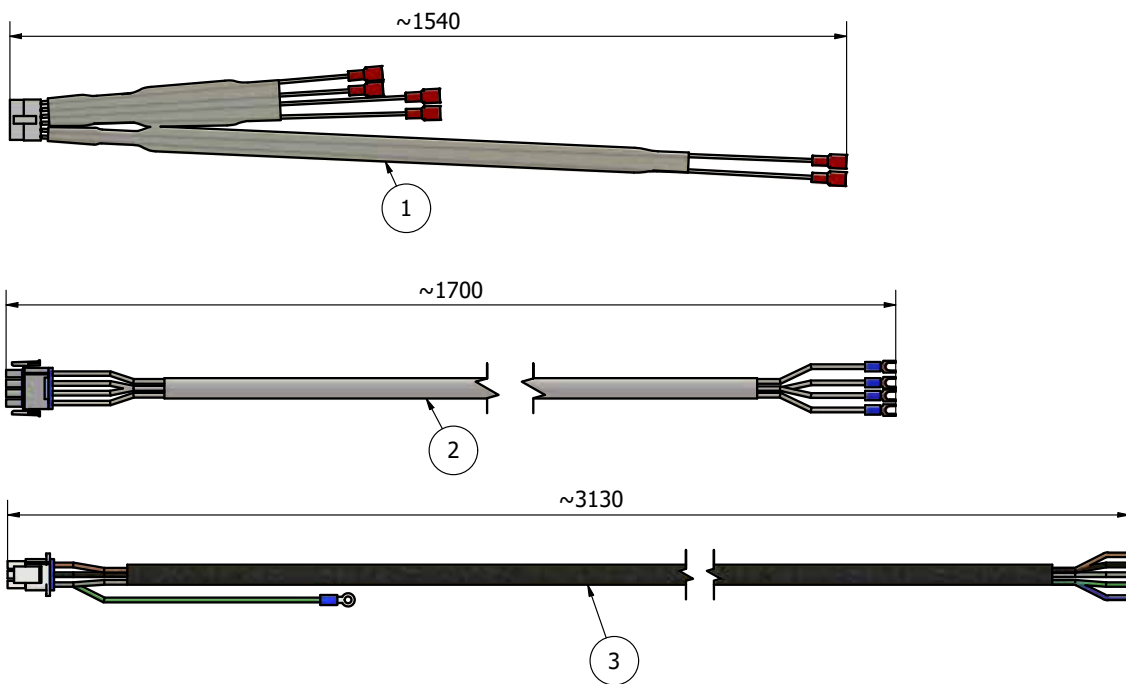

FIG NO.	ORDER NO.	DESCRIPTION
1	AR31-194.19M	Cable, safety switches
2	AR31-194.62M	Motor supply cable
3	AR31-194.53M	Power supply cable, with neutral
	AR31-194.56M	Power supply cable, without neutral



ELECTRIC COMPONENTS

FIG NO.	ORDER NO.	DESCRIPTION
1	*2)	AR10E-430 Isolating transformer
2		AR30-453.1 Physical earth label
3	*1)	AR31-152.1M Enclosure assembly
	*2)	AR31-152.3M
4		AR31-194.18M Safety cable
5	*1)	AR31-194.54M Power supply cable
	*2)	AR31-194.57M
6		AR31-194.63M Motor cable
7		AR31-194.80M Fuse cable
8		AR31-194.81M Fuse cable
9		AR31-194.84M Signal cable
10		AR31-194.85M Signal cable
11		AR31-530.21M Front panel assembly
12		08030-0804 Fuse holder with fuse
12.1		R20E-418.2 Fuse
13	*2)	STA3046 Crimp connector
14		STA5232 Self tapping Screw
15	*2)	STA5250 Screw
16	*2)	STA5896 Hex flange nut
17		STA5897 Hex flange nut

..... *1) .. Without isolating transformer, standard

..... *2) .. With isolating transformer, >380V without neutral

Frequency [Hz]	Voltage [V]	Motor [Item no.]	Power [kW]	Current [A]	Connection	Contactors, [fig.22]	Thermal Overload Relay [fig.23]	Overload relay setting [fig.23a] [A]
50	3x230	R100-85.1	2,9	13	Δ	AR31-88.104	AR31-88.206	16
	3x380-415			7,5	Y		AR31-88.204	9
60	3x480	R100-85.52	3	6,5	Δ	AR31-88.115	AR31-88.206	8
	3x208			13			AR31-88.206	16

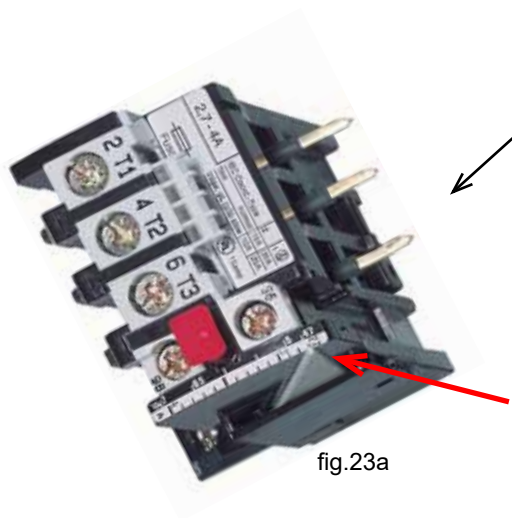
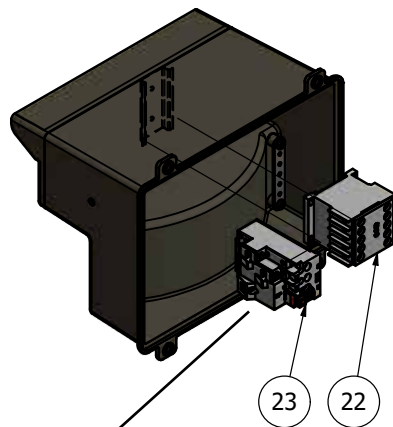
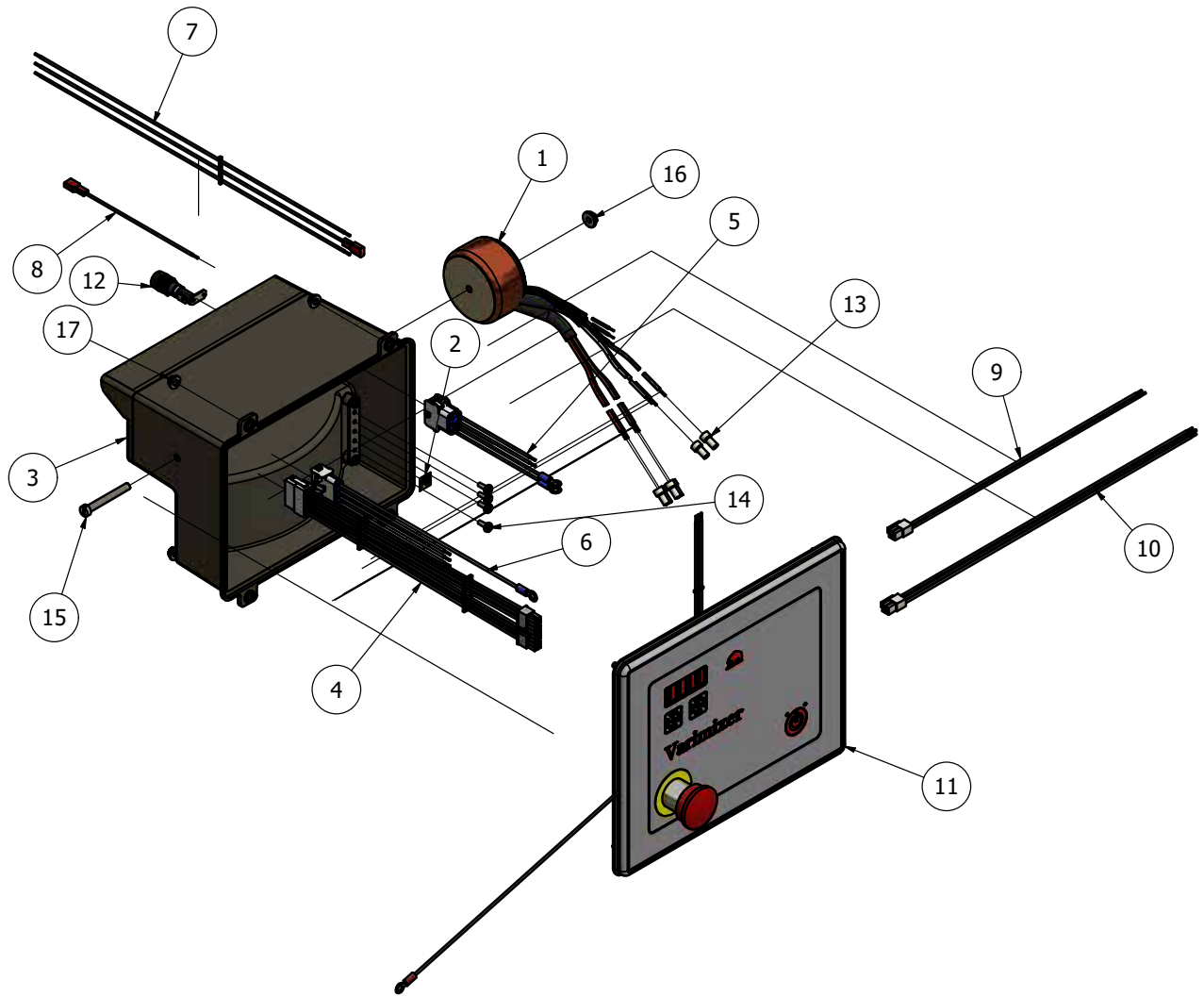

Setting see table page 18

fig.23a

FRONT PANEL ASSEMBLY

FIG NO.	ORDER NO.	DESCRIPTION
1	AR31-174.35.....	Switch emergency stop
2	AR31-174.36.....	Switch mounting Collar
3	AR31-174.37.....	Switch contact block
4	AR31-194.41M.....	Grounding cable
5	AR31-194.82M.....	Supply cable
6	AR31-530.3.....	Front panel
7	AR31-532.10.....	Control board
8	AR31-562.....	Gasket
9	STA5762	Screw
10	STA5897	Hex flange nut

AR31-530.21M

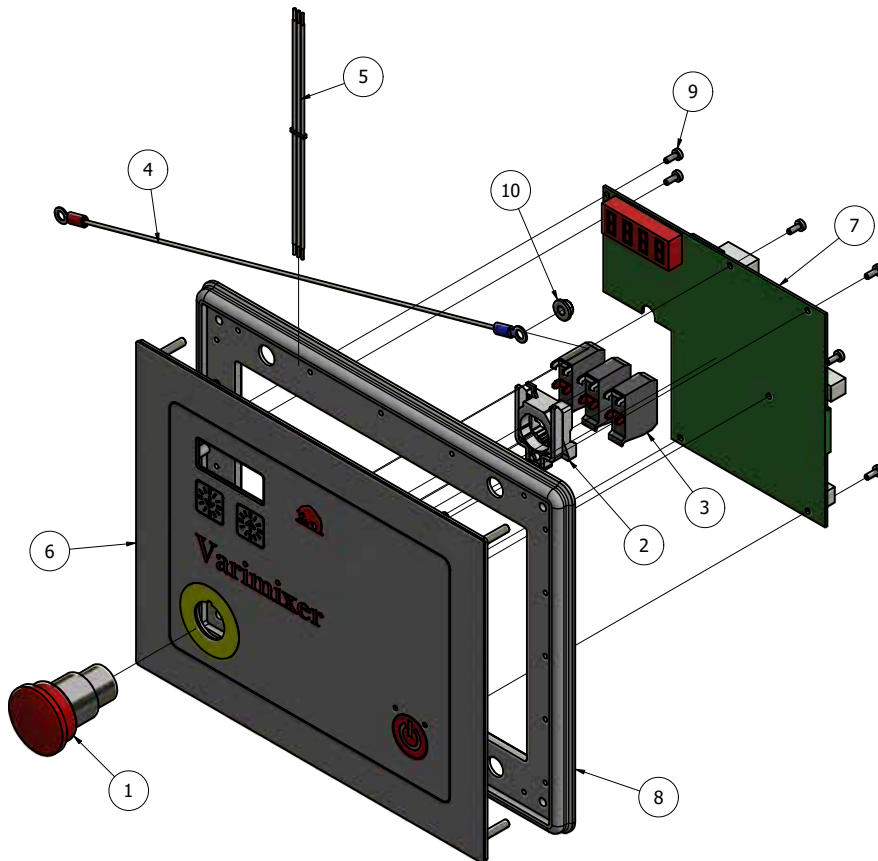

BOWLS AND MIXING TOOLS

FIG NO.	ORDER NO.	DESCRIPTION
1	AR80-75M	A 80 Bowl
1	AR80-75AM	B 80/40 Bowl
2	R100-78M	A Hook
2	R100-78.5M	A Hook, double pin, standard
2	RN100-78BM	B Hook
3	AR80-27.5M	A Flat beater, standard, aluminium, double pin
3	R100-27BM	A Flat beater, aluminium
3	R100-27B2M	A Flat beater, stainless
3	AR80-27.6M	A Flat beater, stainless, double pin
3	RN100-27B2M	B Flat beater
3	RN100-27BM	B Flat beater, aluminium
4	AR80-28M	A Whip
4	AR80-28MT	A Whip with thinner wires
4	RN100-28BM	B Whip
4	RN100-28BMS	B Whip, with thicker wires
5	44AR80	A Whip, reinforced
6	14AR80	A Wing whip No. 14
6	14RN100B	B Wing whip No. 14
7	39AR80	A Powder mixer
8	** 42AR80P	A Scraper with Blade (PA) and holder
8	** 42AR80PT	A Scraper with Blade (PTFE) and holder
8	** 42RN100BP	B Scraper with Blade (PA) and holder
8	** 42RN100BPT	B Scraper with Blade (PTFE) and holder
9	42AR80-202	A Scraper with Blade (PA)
9	42AR80-202T	A Scraper with Blade (PTFE)
9	42RN100B-202	B Scraper with Blade (PA)
9	42RN100B-202T	B Scraper with Blade (PTFE)
10	42R100-105	Scraper holder
11	42AR80-204	A Blade (PA) for scraper
11	42AR80-204T	A Blade (PTFE) for scraper
11	42RN100B-204	B Blade (PA) for scraper
11	42RN100B-204T	B Blade (PTFE) for scraper
12	STA5652	Screw
13	STA6029	Washer
14	48R60Z	A Rack for mixing tools
15	22AR80	A Bowl truck
15a	22AR80A	B Bowl truck
16	22R276	A Bowl truck Handle
16a	22R277	B Bowl Truck Handle (Downsize Bowl)
17	22R100-40	A Bowl truck frame
17a	22R30-41	B Bowl Truck Frame (Downsize Bowl)
18	22R140.3	A Spacer
18	22R140.100	B Spacer
19	STA5608	Hex socket set screw
20	22R30-520	Castor wheel
21	STA5642	Socket head screw
22	STA5676	A Slotted set screw
22a	STA5675	B Slotted set screw

..... All materials Stainless steel, unless otherwise specified

..... ** Adapted by mounting

..... A Full size bowl

..... B Half size bowl

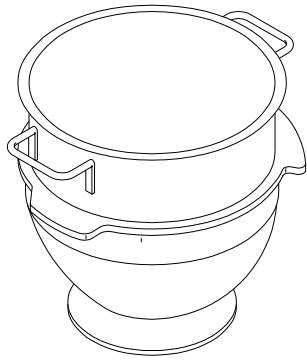

1



2

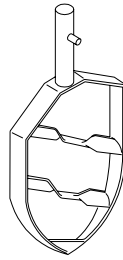

3

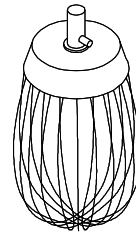

4

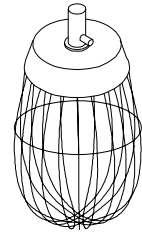

5

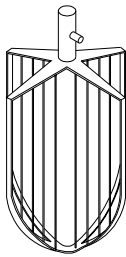

6

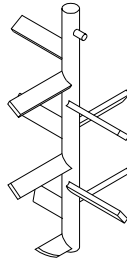

7

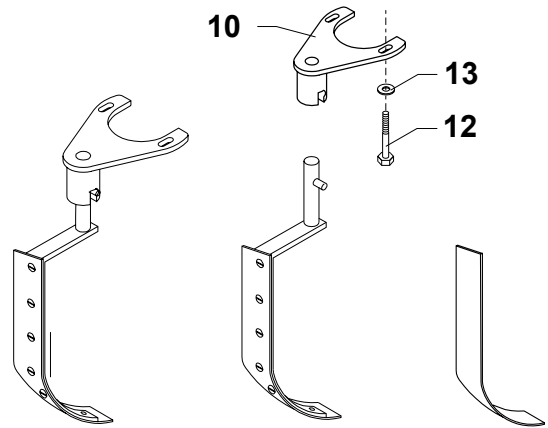

8

9

11

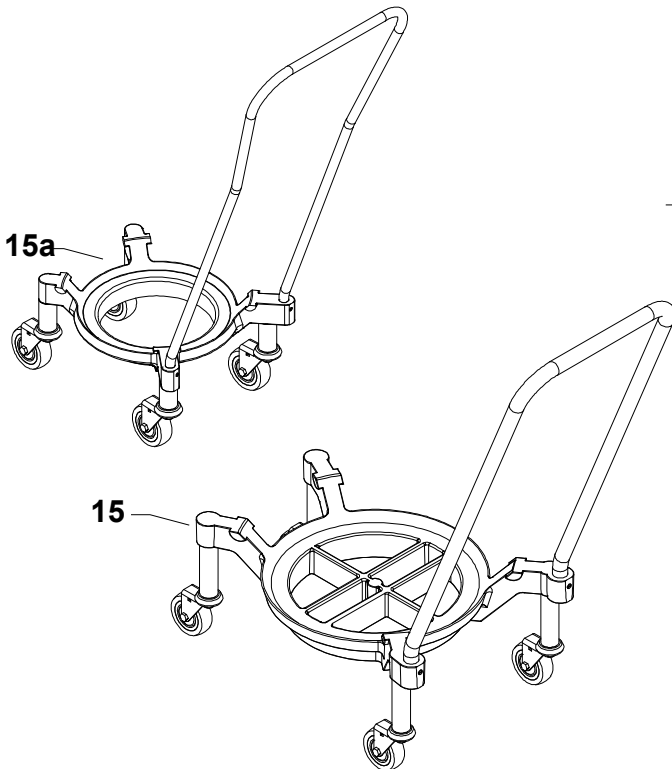

15a

15

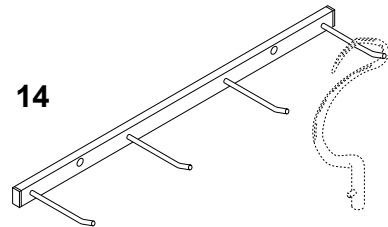

14

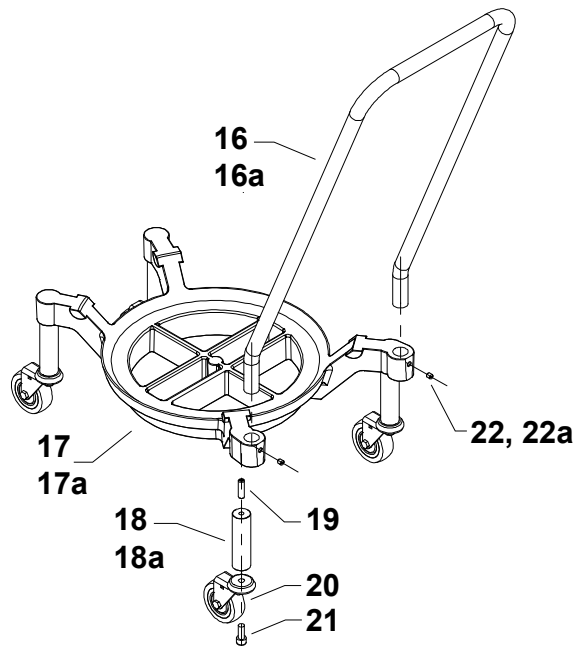

16
16a

17
17a

18
18a

19

20

21

22, 22a



Varimixer

Varimixer A/S
Elementfabrikken 9
DK-2605 Brøndby
P: +45 4344 2288
E: info@varimixer.com
www.varimixer.com