

Varimixer

KODIAK10

Floor model

VERY SIMPLE INTUITIVE OPERATION Set the time and speed. Press start and stop. It's that simple, and everything is controlled at an ergonomic working height from the control panel.

FRONT ATTACHMENT DRIVE KODIAK is also available with an attachment drive for meat mincers and vegetable slicers.

PATENTED DETACHABLE SAFETY GUARD

The guard has an integrated filling tray, is made of transparent plastic and is dishwasher-safe. It can be attached instantly without tools. The guard is held in place by magnets, which also serve as a safety cut-off.

WORLD'S MOST EFFECTIVE TOOL

Unique design increases speed at the periphery and reduces the working time.

IP44 Varimixer KODIAK can be cleaned in line with the IP44 standard.

ERGONOMIC RAISING AND LOWERING

The ergonomically designed handle lowers and raises the bowl and locks it in place in a single movement.

STAINLESS STEEL Made of easy-to-clean stainless steel with a strong frame and high, adjustable legs, to allow cleaning under the machine. The bowl, wire whip, beater, dough hook and scraper are also made of stainless steel and are dishwasher-safe.

RUNS ON 230 VOLTS KODIAK can be connected to a normal power outlet. A frequency converter and a three-phase motor make Varimixer KODIAK a very powerful mixer.

HEIGHT-ADJUSTABLE LEGS

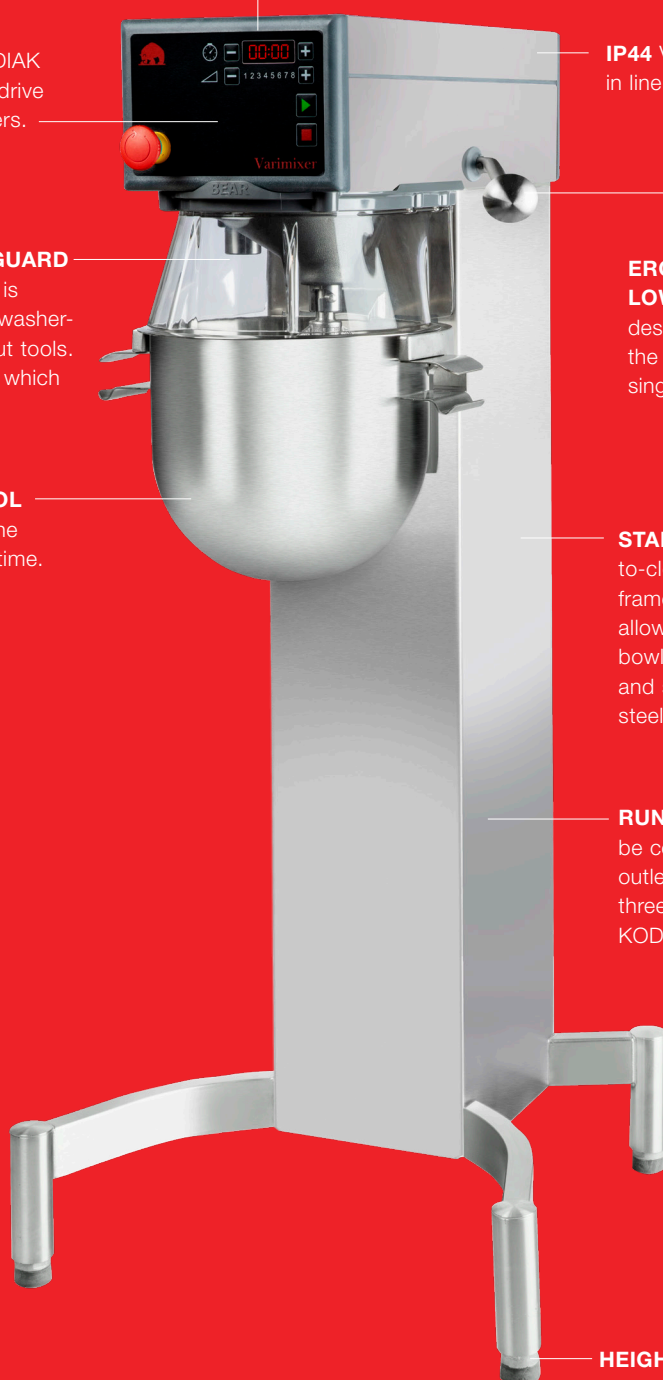

VARIMIXER KODIAK10 OPTIONS – MODELS



Floor model, stainless steel



Marine version, Stainless steel

OPTIONS – ATTACHMENT DRIVE



Attachment drive for meat mincer and vegetable cutter



Meat mincer, stainless steel, 62 mm

VARIMIXER KODIAK10 STANDARD TOOLS



Hook, whip, beater and bowl 10L in stainless steel.

SAFETY GUARD



Removable magnetic safety guard.

ACCESSORIES - TOOLS

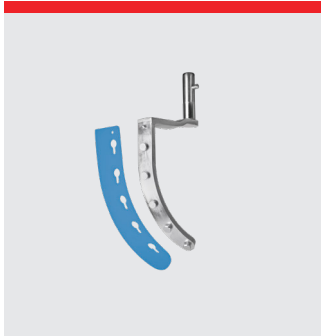

Automatic scraper in stainless steel.



Tool rack, 91 cm

VARIMIXER KODIAK10 STANDARD

Stainless steel construction
Removable magnetic safety guard guard plastic
Digital timer and emergency stop
Scraper holder
1 bowl 10 liter in stainless steel
1 beater in stainless steel
1 hook in stainless steel
1 whip in stainless steel, 3mm wires
Voltage: 1 ph, 230V, 50-60 Hz with 0 and ground. 700 W

VARIMIXER KODIAK10 STANDARD TECHNICAL DATA

Volume	10 l
Effect	700 W
Voltage*	230 V
Residual current devices (RCD):	
Industrial environment	HPFI type A-SI or PFI type B
Light industry/domestic	HPFI type A-SI
Net weight floor model	120 kg
Shipping gross weight	130 kg
H x W x L (Shipping dimensions)	1420 x 680 x 680 mm
H x W x L (Product dimensions)	1197 x 540 x 597 mm
HS Code	84381010
Vol. m ³	0.66 m ³
Ldm	0.19
Variable speed	72 - 451 RPM
Phases	1 ph
IP code	IP44

*Other voltage power supply are available upon request in the range of 100 to 480 V. All standard and marine mixers are available in 50 and 60 Hz.

VARIMIXER KODIAK10 MARINE VERSION - IP CODE: IP44

Slotted free screws. External transformer. Complies with USPHS.

Voltage: 2 ph, 400V, 50-60 Hz, with 0 and ground. 700 W
 2 ph, 440V, 50-60 Hz, with 0 and ground. 700 W
 2 ph, 480V, 50-60 Hz, with 0 and ground. 700 W

CAPACITIES

Tools	Product		Special attention
Whip	Egg Whites	0.5 l	
	Whipped cream	2.5 l	
	Buttercream frosting	4 l	+ □
	Layer Cake Sponges	2.5 kg	
Beater	Mayonnaise	4 l	+
	Mashed potatoes	5 kg	+
	Cakes	5 kg	
	Icing, Fondant	3 kg	+ ○
	Herb Butter	3 kg	+ □
	Meatball / Vegan meatball mix	6 kg	+
Hook	Pasta, noodles (50%AR)	6 kg	●
	Dough, wheat (50%AR)	4 kg	●
	Dough, wheat (55%AR)	5 kg	●
	Dough, wheat (60%AR)	5 kg	○
	Dough, whole wheat (70%AR)	5.5 kg	
	Dough, rye bread	6 kg	+
	Dough, sourdough bread	5.5 kg	
	Dough, gluten free	4.5 kg	

The capacity chart shows the maximum capacity for the specific machine. The testing has been conducted with standard equipment. Therefore, the use of special tools, can result in a different outcome. Always start the machine at the lowest speed. Increase the speed subsequently, taking the product being mixed into account.

Symbols explainer - Recommended actions:

- + = Apply scraper, for the best and most efficient result
- = Always make sure the ingredients are room temperature/soft. If not, this can damage the tools.
- = Recommended to work on low speed.
- = Recommended not to go above medium speed.
- AR = Absorption Ratio (moisture in % of dry matter)

DIMENSIONS

Floor model, **standard**

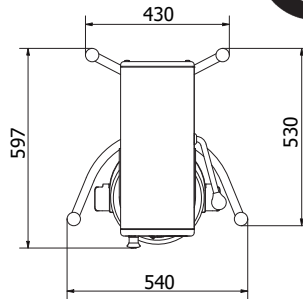
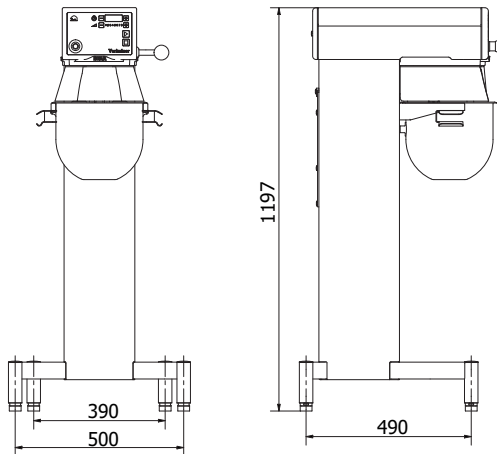

Floor model, **marine**

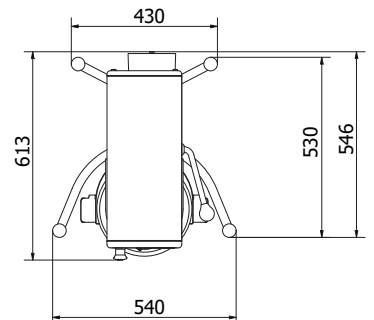
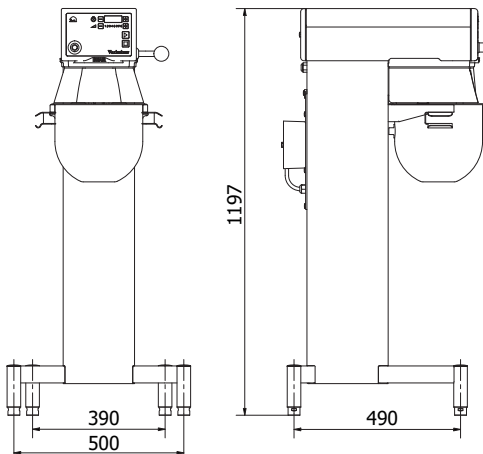

CERTIFICATIONS



Varimixer

Varimixer A/S
 Elementfabrikken 9
 DK-2605 Brøndby
 P: +45 4344 2288
 E: info@varimixer.com
 www.varimixer.com