



Varimixer

New shape

Standardization of knee and foot design across AR30, AR40 and AR60 variants

Improved component quality through a revised design and reduced part variation by standardizing the knee and foot assemblies across the AR product range.



Affected parts:

Knees, feet and spacer blocks used on AR30, AR40 and AR60 stands. The design is standardized across all stand variants. Related spare part kits and service kits have been established with new item numbers to support both legacy and new designs.

Affected sales products:

The previous products AR31-213ZB and AR61-213ZB are replaced by AR31-212.1ZB as part of the standardization of the knee and and foot design, but all three numbers can be bought as spare parts.

Last serial numbers before change:

M030	3000000034
M030A-W-400N1-01	3000500013
M030A-S-400N1S-01	3000800001
V30	3000900003
M040.....	4000000074
M040A-W-400N1-01	4000100063
M040A-W-400N1S-01	4000200003
M040A-S-400N1-01	4000300004
M040A-S-400N1S-01	4000400001
M040AP-W-400N1-01	4000500004
V40-3	4000500005
V40-1	4000600005
AR40PH-400V-3-50HZ.....	4000700009

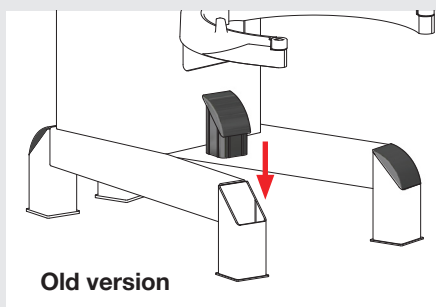

Old version

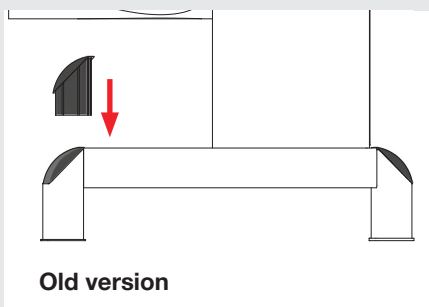

Old version

Reason for change:

To improve the quality of the plastic knee component through updated mould tooling and a revised design. The new design also provides better coverage of the foot, reducing the risk of water ingress. In addition, the knee and foot design has been standardized across AR30, AR40 and AR60 stands, reducing part variation and simplifying inventory management.

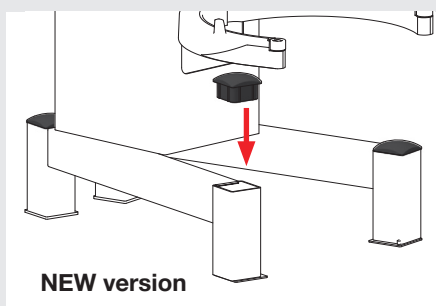

NEW version

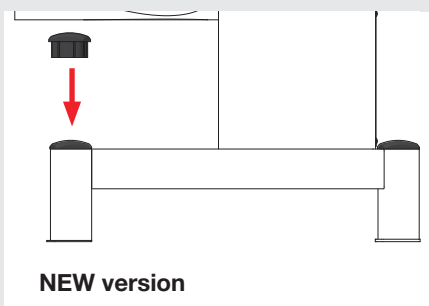

NEW version

Description of change:

Previously, AR30/40 and AR60 used different component designs. The new common design replaces the previous variants, reducing part complexity and simplifying production, inventory management and service support. Production kits and related BOM structures have been updated accordingly.